

Data port using Mini-DIN6 ...

- PIN1 MIC/DATA IN
- PIN2 Ground (GND)
- PIN3 PTT
- PIN5 RX1200 (AUD OUT)
- PIN6 PKS (SQL) - Squelch - COS

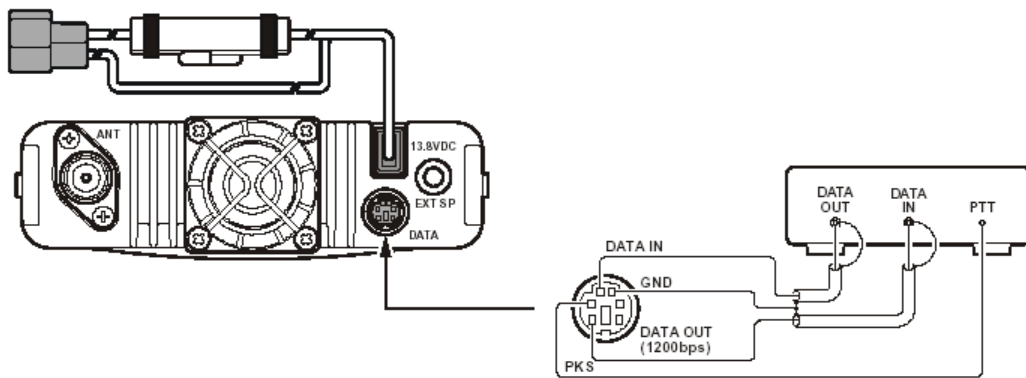

FT8900 DATA PORT	FUNCTION/LEVEL		Interface
PIN 1	DATA IN	40mVp-p Max	MIC TX
PIN 2	GND	Ground (common)	TIE GROUNDS
PIN 3	PTT	Ground to Transmit	PTT
PIN 4	RX9600	Impedance 10kOhm Max Voltage 500mVp-p	NOT CONNECTED
PIN 5	RX1200	Impedance 10kOhm Max Voltage 300mVp-p	MAIN RX
PIN 6	PKS (SQL)	Squelch Control - Squelch Open: +5v Squelch Closed: 0v	COS IN (Set to Go High On Receive)

Simplex (Parrot) Duplex Repeater + Transponder configuration.

For use with two transceivers (FT-8900, FT-8800, etc.)

PC	TRX1 (Radio 1)	TRX2 (Radio 2)	Band	Notes
DTR (4)	PTT (3)	N/C	UHF (Tx 1)	
DSR (6)	SQLCH (6)	N/C	VHF (Rx 1)	

GND (5)	GND (2)	GND (2)	N/A	
RTS (7)	N/C	PTT (3)	VHF (Tx 2)	
CTS (8)	N/C	SQLCH (6)	UHF (Rx 2)	
SPKR L	PKD (1)	N/C	UHF Audio In (Tx 1)	Need Stereo Cable to separate channels.
SPKR R	N/C	PKD (1)	VHF Audio In (Tx 2)	
LINE L	RX1200 (5)	N/C	UHF (Rx 2)	Need Stereo Cable to separate channels.
LINE R	N/C	RX1200 (5)	VHF (Rx 1)	

The repeater can be set to either Left or Right channel. Preference is to have the repeater on the Left channel set to UHF along with the priority set to the repeater. This will allow for the controller, repeater and transponder to be controlled remotely via DTMF.

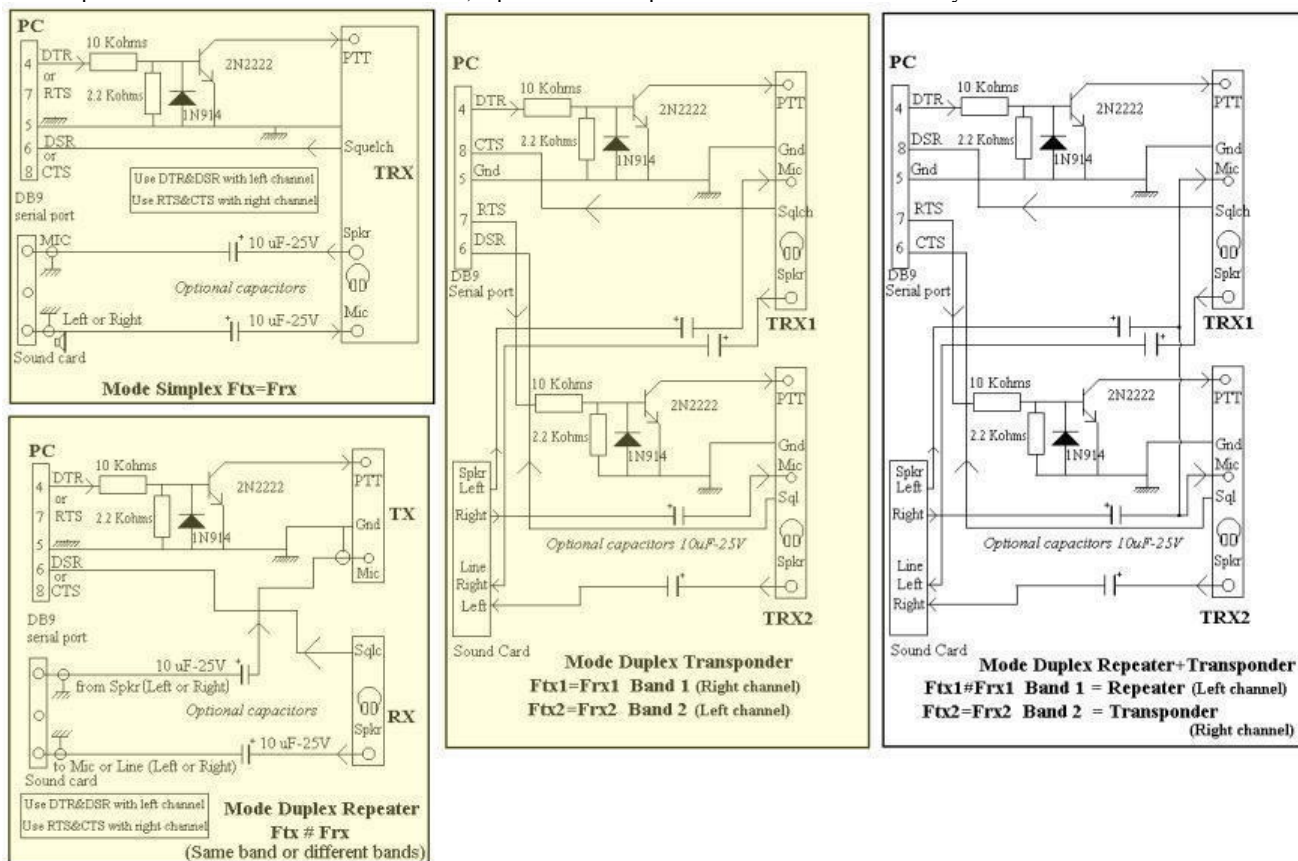

Notes

All connections shielded and grounded as shown in simplex sketch.

In Duplex mode, the sound card must be set so that its input signals are rerouted to its speaker outputs. (See your Windows Sound settings for that)

DTR and RTS signals are +12V when set and -12V when reset. DSR and CTS are set with +9V to +12V and reset at 0V.

The isolation capacitors between sound cards and transceivers are not mandatory if they already exist inside your equipments

If the COM port is a DB25, the pin allocation is : DTR=20, RTS=4, DSR=6, CTS=5, Gnd=7

In Duplex Transponder, use the stereo LINE inputs because Mic input of the sound card is not stereo

Usually, the top contact of a 3.5" stereo jack is the left channel, the middle contact is the right channel and the rear contact is ground

DSR or CTS must be HIGH when active. If your squelch signal is low when squelch is open, insert an inverter between squelch and COM port

In Duplex Repeater+Transponder, if you want TRX2 to be priority holder just set 'Priority on right channel' in the relevant menu of SIMPLEX.

In Duplex Repeater+Transponder, both sound cards outputs and TRX mic inputs are connected together.

If audio is coming from the non-priority TRX2, this TRX2 will not receive the PTT command and will remain in receive mode.

Sketched by Gabriel F6DQM

NOTE: Mode Duplex Repeater + Transponder ... it shows that DB9 Pin 8 is DSR and Pin 6 is CTS. This is reversed. Use DTR (4) and DSR (6) with TRX1 and RTS (7) and CTS (8) with TRX2

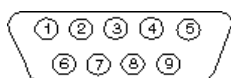

PIN#	SIGNAL	PIN#	SIGNAL
1	N/A	6	DSR
2	RXD	7	RTS
3	TXD	8	CTS
4	DTR	9	N/A
5	GND		

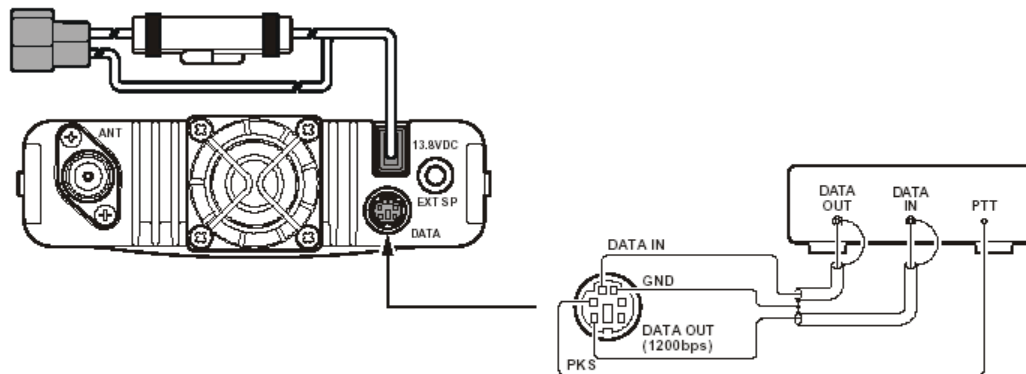

1200bps Packet Setup

FT8900 DATA PORT	FUNCTION/LEVEL		Interface
PIN 1	DATA IN	40mVp-p Max	MIC TX
PIN 2	GND	Ground (common)	TIE GROUNDS
PIN 3	PTT	Ground to Transmit	PTT
PIN 4	RX9600	Impedance 10kOhm Max Voltage 500mVp-p	NOT CONNECTED
PIN 5	RX1200	Impedance 10kOhm Max Voltage 300mVp-p	MAIN RX
PIN 6	PKS (SQL)	Squelch Control - Squelch Open: +5v Squelch Closed: 0v	COS IN (Set to Go High On Receive)

On the newer Yaesu radios they are using a mini-DIN 6 jack, it was primarily designed for handling data for packet radio. Since it is dealing with audible signals it can also be used for RoIP and repeater control. The COS is present within the radio and brought out externally via PIN 6, when a RF signal is detected the squelch control level goes high (to 5vdc). As soon as the RF signal is lost the squelch control level returns to 0 volts.

- PIN 1 DATA IN (to transmitter, audio signal from computer sound card speaker jack)
- PIN 2 Ground (system ground)
- PIN 3 PTT (Push To Talk line, goes to ground to key transmitter)
- PIN 5 RX1200 (DATA OUT, Audio to Interface and Sound Card)
- PIN 6 PKS (Squelch Control, aka COS when rf signal detected line goes high [5vdc] until loss of rf signal)